

THIS COPY IS PROVIDED ON A RESTRICTED BASIS AND IS NOT TO BE USED IN ANY WAY DETRIMENTAL TO THE INTERESTS OF PANDUIT CORP.

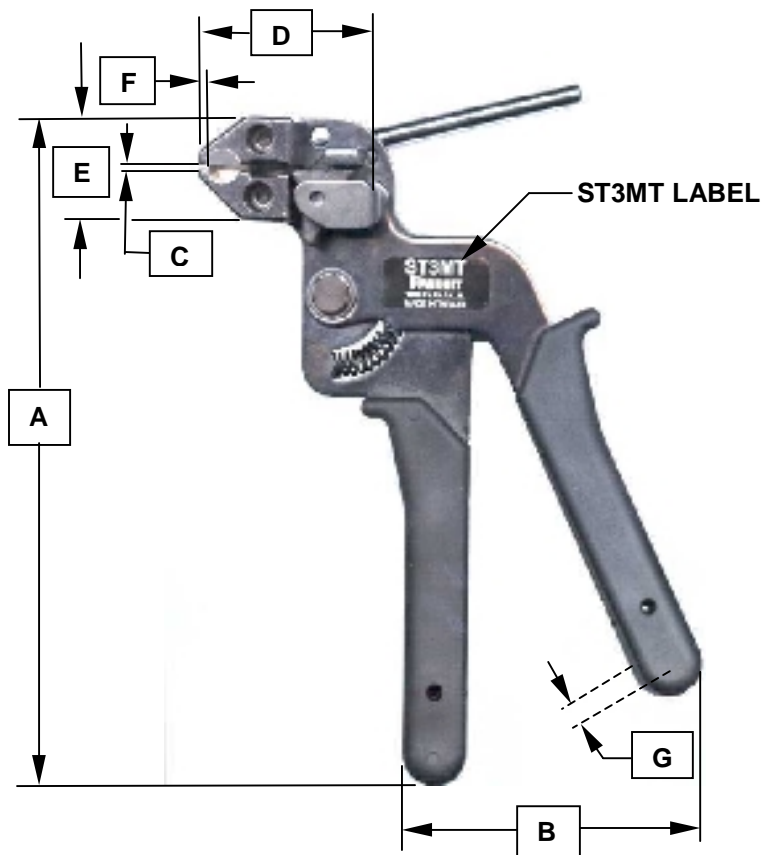

NOTES UNLESS OTHERWISE SPECIFIED :

PANDUIT TOOL NUMBER ST3MT IS USED TO INSTALL ALL PAN-STEEL™ TYPE MLT TIES, TYPE MLTC COATED TIES AND TYPE MLTDH DOUBLE WRAPPED TIES.

THIS TOOL FEATURES INCLUDE:

- Single handle trigger for fast installation
- Cable tie side entry for immediate positioning of tie and tool
- Installer controlled tension
- Cut-off capability with the cutter and cutter handle
- Easy removal of excess tie

CABLE TIE CROSS-SECTION CODE:

MLT = Metal Locking Tie , MLTC = Nylon 11 Coated Stainless Steel Ties,
MLTDH = Double Wrapped Stainless Steel Cable Ties

TOOL WEIGHT = 1.2 LBS. (558 GRAMS)

DIMENSIONS SHOWN IN (PARENTHESIS) ARE METRIC:

A = 8.50 MAX (215.60)	OVERALL LENGTH
B = 4.00 MAX (101.60)	OPEN HANDLE SPAN
C = .025 W x .500 L (.64 x 12.7)	TIE ENTRY
D = 2.13 MAX (54.10)	DEPTH OF HEAD
E = 1.25 MAX (31.80)	HEIGHT OF HEAD
F = 1.13 MAX (28.70)	WIDTH OF HEAD
G = 0.78 MAX (19.81)	HANDLE THICKNESS

F:\Proj\0202832\TB24739A01(ST3MT-CD)

												CORP. TINLEY PARK, ILLINOIS		
										ST3MT CUSTOMER DRAWING				
										UNLESS OTHERWISE SPECIFIED, DIMENSIONAL TOLERANCES ARE:		UNLESS OTHERWISE SPECIFIED, ALL DIMENSIONS ARE GIVEN IN INCHES, THIRD ANGLE PROJECTION.		
										(.x) ± --- (.xxx) ± ---				
										(.xx) ± --- ANGLES ± ---				
										DRAWN BY: WDE	MATL: -----	SCALE NONE		
										DATE: 06/24/03		DRAWING NO. TB24739A01	DWG A SIZE	
										CHK'D: ABJ				
00	06/24/03	WDE	ABJ	RELEASED	4097	--	DLWE							
REV	DATE	BY	CHK'D	DESCRIPTION	ECN	-R	CUST	SUP						